



THE SSB-600



TUBES

HAM NEWS

GROUNDING-GRID LINEAR AMPLIFIER

— 600 Watts DC Input in 600 Cubic Inches

By A. F. Prescott, W8DL

FEATURES —

1. Efficient high frequency pi-network output circuit;
2. Complete metering of each tube;
3. Two GL-814 pentodes in zero-bias triode connection;
4. Rugged, compact construction for mobile service;
5. Covers 3.5 to 30 megacycles;
6. Only 6 x 10 x 10 inches in size.

You probably remember the old saying, "Do as I say, not as I do." W8DL has been *saying* how to build this mobile SSB linear amplifier for years, after first constructing a model from *junk-box* parts. He recently has been *doing*, instead of saying, however, by constructing a new — and much prettier — model of his amplifier especially for this publication.

Over five years of testing in mobile and fixed service have been chalked up by the original model. It has several worthy electrical and mechanical features that make it stand out from being "just another linear amplifier."

THE GL-814 BEAM PENTODE was chosen for an amplifier tube because, when connected as a triode (control, screen and suppressor grids all connected together and returned to the filament) it exhibits zero bias characteristics and draws only 25 milliamperes of plate current with 2,000 plate volts applied. Since the rated plate dissipation of the GL-814 is 70 watts in ICAS¹ service, it was decided to connect two tubes in parallel to obtain about 600 watts DC input

¹Intermittent Commercial and Amateur Service ratings.

(continued on page 2)

W8DL and W8WFH (right) run the SSB-600 linear amplifier through power-output tests. Equipment includes SSB exciter (left), modified BC-453 Command Set receiver, SSB-600 amplifier, and commercially-made r.f. wattmeter and dummy antenna load. W8DL is supervisor of the Electronics Laboratory at General Electric's Cuyahoga Lamp Plant; and W8WFH, William C. Louden, is technical counselor in Discharge Advance Engineering at G. E.'s Large Lamp Department, both at G. E.'s Nela Park in Cleveland, Ohio. W8DL and W8WFH recently authored the **G-E HAM NEWS** series of articles on high-power Mobile Radio Systems, including Power Supply Ideas, Crystal Controlled Converters and a BC-453 Command Set receiver conversion, and a high-power Mobile Linear Amplifier with two GL-4D21/4-125-A's in parallel.

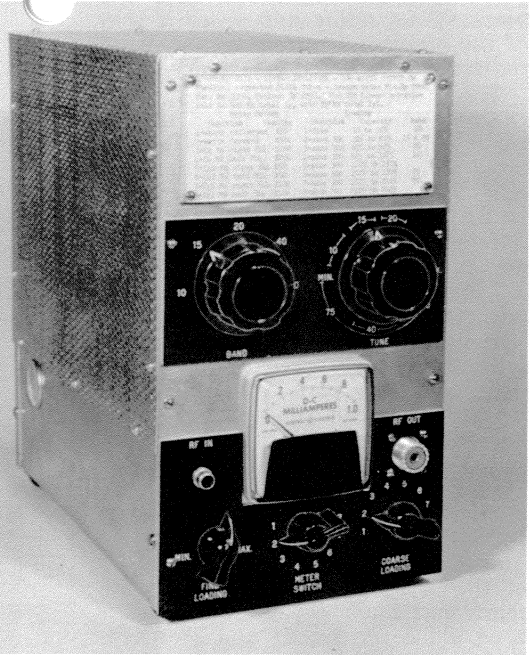

CLOSEUP FRONT VIEW of the SSB-600 amplifier. Note complete operating instructions at top of panel (see copy on page 7). Markings for panel controls were engraved on black plastic name plate material.

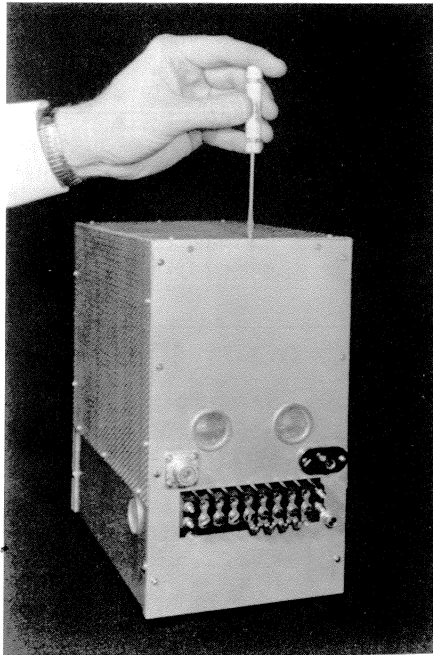

REAR VIEW of the amplifier. Locations for J₃, J₄, the high voltage connector, and terminal strip TS₁ can be determined from this view. Note ventilating snap-in buttons on sides and back.

IN THIS ISSUE

SSB-600 Grounded-Grid Linear Amplifier.....page 1
 Simple Sensitive Multimeter.....page 6
 1960 Edison Radio Amateur Award — Recipients.....page 8

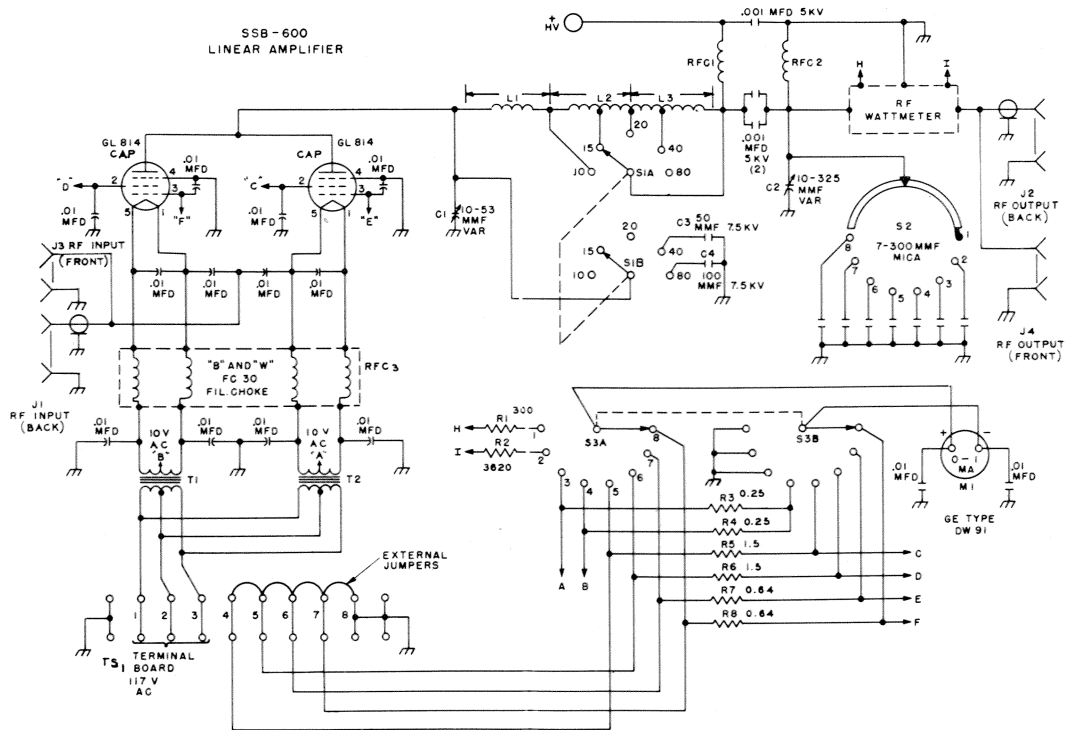

FIG. 1. SCHEMATIC DIAGRAM for the SSB-600 grounded-grid linear amplifier. Note the dual r.f. input (J₁ and J₃) and output (J₂ and J₄) jacks; one set of each is on the front and rear panels. The extra set is handy for picking up samples of the input and output signals for testing. The three 0.001-mfd. 5-KV capacitors in the plate circuit for DC blocking and bypassing are Centralab type 858S-1000 cylindrical

ceramic capacitors. If separate metering of currents drawn by each tube is not necessary, a single 10-volt, 7-ampere filament transformer, and B & W FC-15 single filament r.f. choke can be used in place of the components shown. All bypass capacitors are 600-volt working disc ceramics, unless otherwise marked. Use terminals 1 and 2 on TS₁ for 105-volt AC input to the filament transformers.

SSB-600 (continued from page 1)

capability in the low duty-cycle SSB and CW classes of service.

The grounded-grid circuit was selected because it eliminates a tuned input circuit in the linear amplifier. Also, sufficient driving power was available — about 40 to 50 watts — to drive the two GL-814 tubes in a grounded-grid, triode connected circuit, to full output. Driving power is fed directly into each side of each GL-814 filament through 0.01-mfd.

disc ceramic capacitors, as shown in the schematic diagram, Fig. 1. A commercially made filament choke isolates r.f. energy from the filament transformers, T₁ and T₂. Cathode input impedance is 100 to 200 ohms, depending on frequency.

The plate circuit is a pi network, with high voltage series fed through an r.f. choke (RFC). This permits more inductance to appear in the pi network on 28 megacycles. When parallel feed is used for plate voltage

application the distributed capacitance of the r.f. choke and DC blocking capacitor appear as a part of the input capacitance across the pi network, which is very undesirable.

When the output capacitance of the amplifier tubes is added to this input capacitance, it often is impossible to realize a desirable tank circuit "Q" on 28, and sometimes even on 21 megacycles. The need for parasitic chokes in the tube plate leads also is eliminated.

This circuit also has been tested with four tubes connected in parallel without encountering parasitic oscillation. The only precaution was to use four tube plate leads of equal length to the common point of parallel connection.

Bandswitching of the pi-network circuit was achieved with a tap switch (S_{1A}) to short out sections of the inductance (L₁, L₂ and L₃) as required. The input tuning capacitor of the pi network (C₁) has only 50-mmf maximum capacitance, and is used alone for 14, 21 and 28 megacycles. Another section of the bandswitch (S_{1B}) adds a 50-mmf fixed vacuum capacitor (C₃) for 7 megacycles, and a 100-mmf vacuum capacitor (C₂) for 3.5 megacycles. This system permits selecting a tuning capacitor with low minimum capacitance and good ease of tuning for the higher frequencies, and still have sufficient capacitance for good circuit "Q" at 7 and 3.5 megacycles.



**presents HOW-TO-DO-IT IDEAS
from the 999 radio amateurs at
GENERAL ELECTRIC**

A bi-monthly publication of the RECEIVING TUBE DEPARTMENT
Owensboro, Kentucky, U. S. A. • Editor — E. A. Neal, W4ITC

G-E HAM NEWS is available free from authorized G-E Tube distributors. Some distributors mail copies locally to their customers.

A low-cost direct-mail subscription plan is available to persons residing in the United States and its possessions (including APO and FPO numbers).

Subscription rates are:

One Year (6 issues).....	\$1.00
Two Years (12 issues).....	\$2.00
Three Years (18 issues).....	\$3.00
Five Years (30 issues).....	\$4.00

Enclose check or money order for U. S. currency for the proper amount above made payable to "General Electric Company."

Residents of Canada may subscribe to G-E HAM NEWS for \$1.00 per year from the Canadian General Electric Company, Ltd., Electronic Tube Market-

ing Section, 189 Dufferin Street, Toronto 3, Ontario, Canada. Enclose check or money order made payable to: "Canadian General Electric Company, Ltd."

Distribution of G-E HAM NEWS in more than 40 foreign countries is handled through the International General Electric Company. A listing of outlets is available from the G-E HAM NEWS office. Or, write to: Customer Inquiry Section, International General Electric Company, 150 East 42nd Street, 7th Floor, New York 17, New York, U. S. A.

NOTE: The disclosure of any information or arrangements herein conveys no license under any patents of General Electric Company or others. In the absence of an express written agreement to the contrary, the General Electric Company assumes no liability for patent infringement (or any other liability) arising from the use of such information by others.

TABLE I — PARTS LIST

- C₁.....10-53-mm variable, 0.125-inch air gap (Johnson 50E45, Cat. No. 154-12).
 C₂.....10-325-mm variable, 0.025-inch air gap (Hammarlund MC-325-M, or equivalent).
 C₃.....50-mm, 7,500-volt fixed vacuum capacitor (G. E. 1L38, or equivalent).
 C₄.....100-mm, 7,500-volt fixed vacuum capacitor (G. E. 1L33, or equivalent).
 J₁, J₂.....midget one-pin phono type connectors.
 J₃, J₄.....chassis type coaxial jack. (SO-239).
 L₁.....0.65 uh., 5 turns, 3/8-inch diameter copper tubing, 1 1/4 inches inside diameter, 1 3/4 inches long (28-Mc. coil).
 L₂.....2 uh., 5 turns, 1/8-inch diameter copper tubing or wire, 2 1/4 inches inside diameter, 3/4 of an inch long, tapped at 2 turns from L₁ end (14 & 21-Mc. coil).
 L₃.....9 uh., 14 turns, No. 12 finned copper wire, 2 1/2 inches in diameter, 2 3/8 inches long, tapped at 5 turns from L₂ end (7 & 3.5 megacycles) (B & W No. 3905-1 coil stock, or equivalent).
 M₁.....0—1-milliamper DC meter, 2 1/2-inch square flange (G. E. DW-91).
 R₁.....300 ohms, 1 watt total, precision type.
 R₂.....3620 ohms, 1 watt, precision type.
 R₃, R₄.....0.25 ohms, 1 watt, precision type.
 R₅, R₆.....1.5 ohms, 1 watt, precision type.
 R₇, R₈.....0.64 ohms, 1 watt, precision type.
 RFC₁.....100-uh. solenoid type single layer r.f. choke; 140 turns of No. 26 enameled wire closewound 2 1/2 inches long on 3/4-inch diameter ceramic pillar 3 inches long.
 RFC₂.....2.5-mh, 250-milliamper pi-wound r.f. choke (National R-300, or equivalent).
 RFC₃.....Dual 15-ampere filament r.f. choke (B & W FC-30).
 S₁.....5-position, 2 pole, heavy-duty rotary tap switch (Shallcross type 12609² or Radio Switch Corp. No. 86 Standard).
 S₂.....10-position, 1 pole, progressive shorting rotary tap switch (Centralab No. 2042).
 S₃.....8-position, 2 pole rotary tap switch (Centralab No. 1413, 11 positions).
 T₁ T₂.....10-volt, 4-ampere filament transformer, 115-volt primary (Stancor P-5016, or P-6458; Thordarson T-21F18).

²Shallcross Manufacturing Co., Selma, North Carolina. See manufacturers' representatives listing in Electronics Buyers Guide for nearest distributor.

The same reasoning was applied to the loading capacitance (C₂). A 10 to 325-mm variable is used for the higher frequencies, and additional capacitance, up to 2,100 mmf, is cut in by S₂ in steps of 300 mmf. RFC₂ is a safety choke.

THE METERING CIRCUIT provides for measuring control and screen grid, and cathode currents in each GL-814 individually. This permits selecting a matched pair of GL-814's (if you happen to have spares around), and is also handy for insuring that each tube is sharing the load.

It also allows you to catch a tube starting to go bad before it has a chance to wreck its mate. Many poor signals are caused by weak tubes, causing the other tubes in parallel to be overloaded or to work under improper loading conditions.

Control grid (No. 1 grid) current is normally considered of great importance. This amplifier also has number two grids metered independ-

LEFT SIDE VIEW, showing how C₃, C₄, RFC₂ and S₁ are mounted on ceramic pillars. Coils L₂ and L₃ are cemented to plastic strips supported on ceramic pillars.

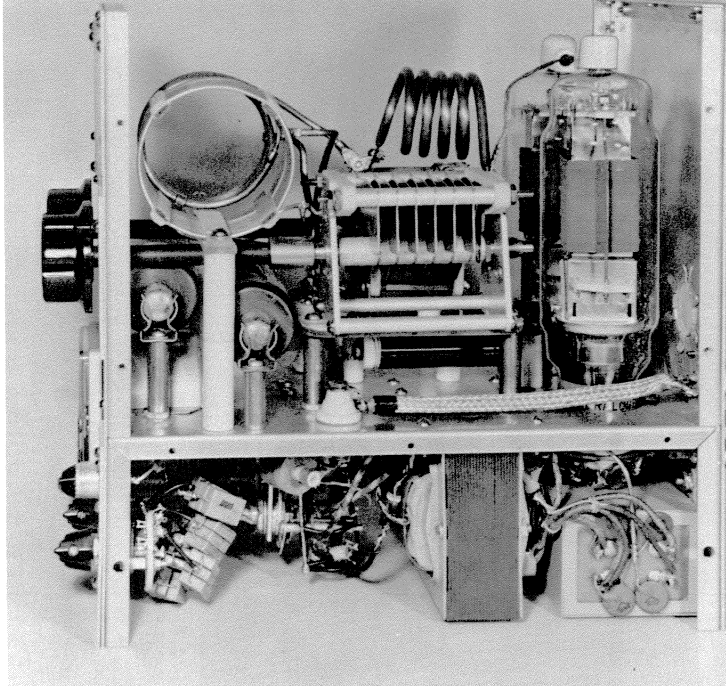

RIGHT SIDE VIEW, showing metal pillars for grounded ends of C₃ and C₄. Insulated shafts are used for C₁ and S₁ extensions to the panel knobs. GL-814 tube sockets are sub-mounted 1/2 inch on pillar insulators.

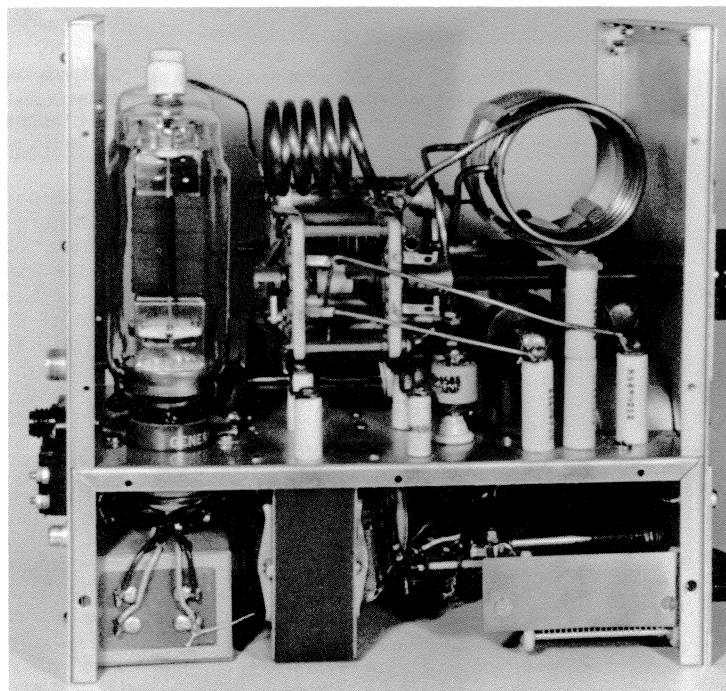

ently. A "look-see" in this circuit is not only interesting but educational. This eliminates guessing as to the division of the drive between the control grid and screen grid.

The cathode circuits are metered in the filament center tap. Remember to subtract control grid and screen grid currents from this reading to determine true plate current. Normal cathode current may be read, but it may be abnormal grid current due to drive and loading that is responsible for this reading.

W8DLD also has built an r.f. wattmeter right into this amplifier. The circuit is described in the May-June, 1961 issue. (See LOW-COST RF WATTMETER, page 1.) Forward power up to 500 watts full scale is read in position 1 of S₃; and, reflected power up to 50 watts full

scale is read in position 2. Thus, readings of nearly 500 watts forward and less than 50 watts reflected power indicate less than 10 per cent reflected power, and a VSWR of less than 2 to 1. The reflected power position can be precisely calibrated with a 50-ohm dummy load.

CONSTRUCTION OF THIS MODEL was accomplished in a 6 x 10 x 3 1/2-inch deep chassis box (Bud CU-3010A Minibox, or equivalent). The parts layout shown in the accompanying pictures and chassis layout drawing, Fig. 2, provides very short r.f. circuit leads and good isolation of the input circuit. Nearly all of the 600 cubic inches of volume in the enclosure are occupied, as readers will note.

The complete enclosure should be constructed first. The 6 x 10-inch end

(continued on page 4)

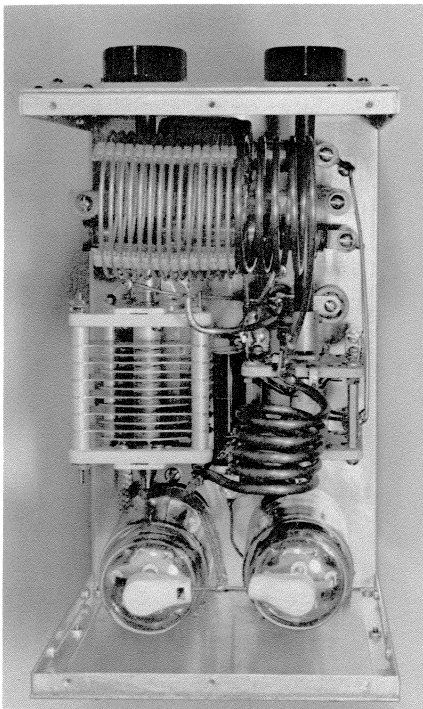

TOP VIEW of the SSB-600 amplifier. Details of tank coil mounting and connections are shown in this view. Allow enough slack in GL-814 plate lead to remove plate caps.

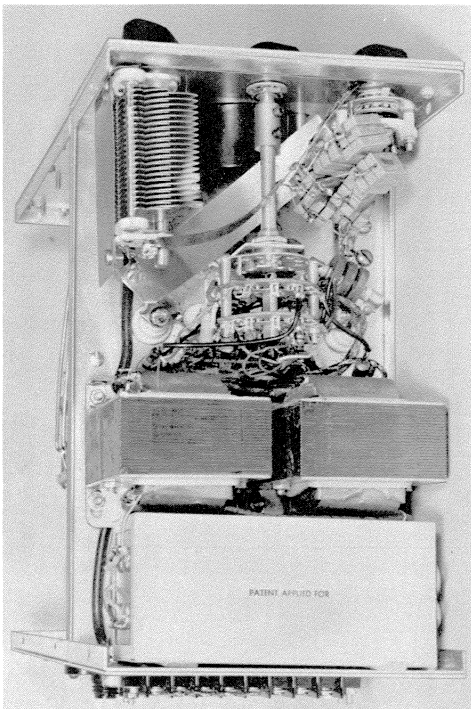

BOTTOM VIEW, showing heavy copper strip connections between C_2 , S_2 and the seven 300-mmf. loading capacitors. The FC-30 filament r.f. choke mounts beneath the GL-814 sockets.

SSB-600 (continued from page 3)

plates were cut from $\frac{1}{8}$ -inch thick sheet aluminum. Pieces of $\frac{1}{2} \times \frac{1}{2} \times \frac{1}{2}$ -inch aluminum angle were then fitted to form a flange to which the shield is fastened. About 38 inches of angle stock is required. If sheet metal bending equipment is available, these flanges could be formed on the end plates.

Perforated sheet aluminum (Reynolds or equivalent) about $10\frac{1}{8} \times 20$ inches is then folded to form the shield cover, as shown in the pictures. The complete enclosure becomes quite rigid when the shield and bottom cover are in place, despite its light weight. The enclosure is then disassembled, including removing front and back panels, to layout and drill holes for the components. Panel layout is shown in Fig. 3.

After punching and drilling holes for the major components, a shield for the meter (M_1) is fabricated as shown in the drawing, Fig. 4, and fastened over the cutout in the chassis to protect the meter from the r.f. field around the plate circuit.

The larger components should be mounted and wired into place. Note that pieces of thin sheet copper flashing have been placed under the chassis between the loading capacitor (C_2) and capacitor switch (S_2) to provide a low-resistance path for the high r.f. currents in this circuit. Copper strip $\frac{1}{2}$ inch wide is used for connecting leads in this circuit. This pays off in higher efficiency at 21 and 28 megacycles. A copper-clad or solid copper chassis also would help the efficiency, if available.

Components for the r.f. wattmeter should be mounted underneath in the center of the chassis before the meter switch, S_3 , is assembled. Bypass capacitors and other wiring around the tube sockets are installed before the filament r.f. choke is mounted. Return as many bypass capacitors as possible to a common chassis ground. A terminal strip (TS₁) was installed on this model for external power connections, but a suitable multiple-pin jack and plug can be used if desired.

Provision for remote measurement of control and screen grid currents is made by connecting the appropriate current meter between terminals 4 to 7, as follows:

- 4 to ground: G-2 (right) 50 ma.
- 5 to ground: G-2 (left) 50 ma.
- 6 to ground: G-1 (right) 100 ma.
- 7 to ground: G-1 (left) 100 ma.

ALL COMPONENTS in this amplifier have been chosen to handle higher power. Thus, a pair of GL-813 beam pentodes could be substituted for the GL-814's if the chassis is made larger; 7 x 12 x 4 inches (A Bud CU-3011A Minibox, or equivalent). However, this size chassis also will hold four type GL-814's in parallel, if anyone prefers to run four of these tubes. Larger filament transformers will be required, of course.

If a pair of GL-813's are used, a well regulated negative bias supply will be required to furnish the approximately minus 70 volts of control grid bias required to hold the plate current to a low value with the triode connection. For this your signal would be 3 DB louder at your

friend's receiver. This is less than one S unit. It is frequently easier to gain 3 DB with a little antenna work than by many hours and dollars spent on the linear amplifier.

Some amateurs may want to construct this amplifier as a subassembly to go into a chassis that includes a power supply. This chassis may also include a driver amplifier for use with an exciter delivering less than 50 watts output. When built as an assembly to go into a chassis cabinet arrangement the "do it yourself" enclosure construction is not necessary.

The small package, complete amplifier described herein was constructed because it was meant to serve mainly for mobile operation.

ADJUSTMENT AND TUNEUP of this amplifier, after construction is completed, should be done carefully to avoid overloading the tubes for extended periods and thus damaging them. Connect 117 volts AC to terminals 1 and 3, and J_1 to an exciter capable of delivering about 50 watts; the output jack, J_2 , to a 50-ohm dummy antenna load capable of dissipating 500 watts; and the "HV" terminal to a power supply delivering about 1,500 volts DC at 300 ma.

Turn on heater power, high voltage, and apply about 5 watts of driving power at 3.9 megacycles. Set S_1 to the 3.5-megacycle position and adjust the plate circuit tuning (C_1) and loading (C_2) capacitors for maximum output with S_2 in position 2 (RF output, forward).

Increase the driving power to about 25 watts and readjust the tuning for maximum output. Then increase the driving power so that 40 milliamperes of grid current is read for each GL-814 in positions 7 and 8 of S_2 . Again adjust the tuning and loading controls for maximum output. If the amplifier is delivering about 300 watts output, then reduce the driving power a bit and readjust the tuning and loading controls. Output power should be close to the maximum value obtained above.

For test purposes, increase the plate voltage to about 2,400 volts DC and tune carefully for maximum output, running the amplifier for only a minute at a time. It should be possible to obtain 500 watts CW output on all bands from 3.5 to 28 megacycles at 2,400 plate volts, and with a maximum of 40 milliamperes of control grid current per tube. Cathode current will read about 200 milliamperes per tube. At 2,000 to 2,250 plate volts, the amplifier will deliver about 400 watts at 28 megacycles, and 450 watts below 21.5 megacycles.

Frequently it happens that an exciter capable of delivering 100 watts power output into a dummy load will not supply the necessary drive to the cathode circuit of a grounded-



SIMPLIFIED SENSITIVE MULTIMETER

By Charles A. Starks, W2URP

A SENSITIVE DC MULTIMETER is always a handy instrument in the amateur radio station. However, complex instruments of this type can be expensive.

"But, they don't have to be," says

W2URP adjusts the control grid bias in his SSB transmitter with his Simplified Sensitive Multimeter. Well-equipped station — and workshop too — includes kilowatt linear amplifier next to SSB transmitter, and matching receiver to right of amplifier. W2URP is an engineer in the Power Rectifier Engineering section of General Electric's Power Tube Department at Schenectady, N.Y. Chuck's favorite bands are 3.9 and 7-MC. SSB, and 7-MC. CW.

Chuck, W2URP. "Look at my simple, sensitive DC voltmeter that the average amateur can duplicate in a single evening.

"I needed a DC voltmeter with very high resistance to check and precisely adjust the negative bias on the control grids of the output stage in the new SSB transmitter I added to my station recently. A conventional 1,000 ohms-per-volt meter would have loaded down the circuit excessively and given me a lower-than-actual reading.

"A quick scan through my junk box under the workbench turned up a 100-microampere DC current meter, a sloping panel meter box, and some miscellaneous banana plugs and jacks, terminal boards and hardware.

"A few minutes of figuring with a pencil — after referring to the 'Measurements' chapter of the *Radio Amateur's Handbook* — and I had the multiplier resistance values required for several popular DC voltage ranges. I used the following formula to calculate the multiplier values: $R = \frac{1000E}{I}$; where R is the

resistance in ohms; E is the desired full-scale voltage; and I is the full-scale reading of the meter in milliamperes. The 100-microampere meter thus gave a sensitivity of 10,000 ohms per volt.

"Rather than switch in the various multipliers with a tap switch, I decided that each multiplier could be mounted on a terminal board that would plug into the back of the meter case. This provided for future needs by allowing additional ranges to be added at any time."

This is the philosophy with which the Simplified Sensitive Multimeter was designed.

THE CIRCUIT of the multimeter is extremely simple, as shown in the schematic, Fig. 1. Multipliers plug into J₄ and J₅, and the leads running to the circuit to be measured plug into J₁ and J₂. Provision can also be made to measure currents with this instrument by plugging in a shunting resistance of suitable value across the meter at J₃ and J₅.

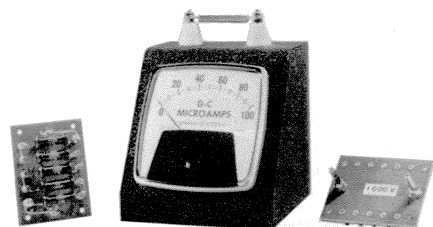

CLOSEUP VIEW of Simplified Sensitive Multimeter with boards containing multiplier resistors beside it. Shunt for measuring current also can be connected between feedthru terminals, as shown here. CAUTION: Exposed terminals and multiplier strip should be covered with insulation when high voltage circuits are being measured.

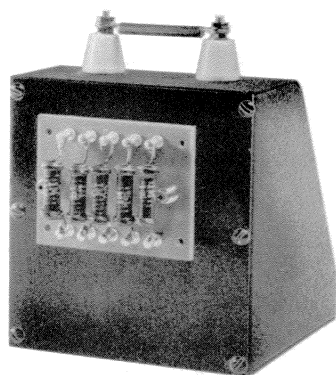

REAR VIEW of meter showing multiplier board plugged into J₄ and J₅ on rear of meter box. A multiplier with a single resistor can be made from a narrow strip of insulating board, with the resistor connected between soldering lugs on the plugs.

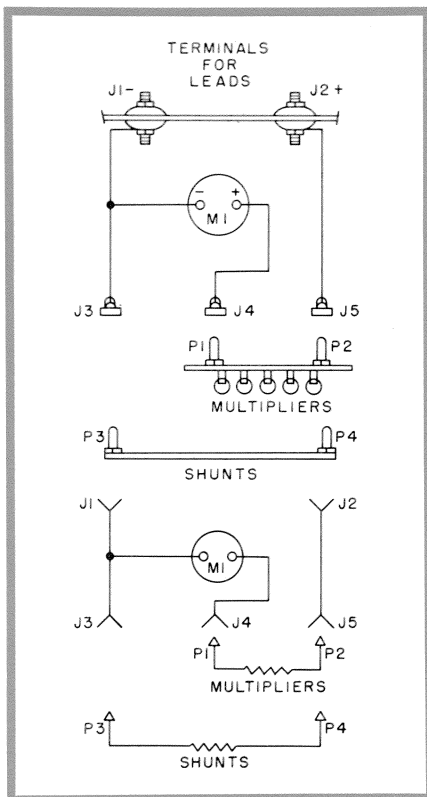

Fig. 1. Schematic diagram of the simple multimeter. Terminals J₁ and J₂ are feedthru insulators with either stud terminals or banana jacks. Jacks J₃, J₄ and J₅ are banana jacks for the multipliers and shunts. Plugs P₁ and P₂ are mounted on the insulating boards holding the multiplier resistors. Plugs P₃ and P₄ are on the shunting resistances.

TABLE I — METER MULTIPLIER CHART

Full Scale Meter Reading Desired	Multiplier for 20 ua meter	Multiplier for 50 ua meter	Multiplier for 100 ua meter	Multiplier for 250 ua meter	Multiplier for 500 ua meter
0.1 Volt	5,000 ohms	2,000 ohms	1,000 ohms	400 ohms	200 ohms
1.0 Volt	50,000 ohms	20,000 ohms	10,000 ohms	4,000 ohms	2,000 ohms
10.0 Volts	0.5 megohm	0.2 megohm	0.1 megohm	40,000 ohms	20,000 ohms
100 Volts	5 megohms	2.0 megohms	1.0 megohm	0.4 megohm	0.2 megohm
1,000 Volts	50 megohms	20.0 megohms	10.0 megohms	4.0 megohms	2.0 megohms

**GROUNDING GRID — LINEAR AMPLIFIER —
500 WATTS OUTPUT CW**

Parallel connected GL814 tubes — Design data: Min. EP 2000 Max. EP 2500, Optimum EP 2250. For SSB Linear operation load to 300 MA total IP, with 75MA total Igl.

Meter Switch		Loading		Band
Position	Reading	Position	Capacity	
1 = watts reflected	X50	1 = fine	10 to 325	10
2 = watts forward	X500	2 = adds 300	325 to 625	15 to 20
3 = 1k MA right 814	X250	3 = adds 300	625 to 925	20
4 = 1k MA left 814	X250	4 = adds 300	925 to 1225	40
5 = Ig2 MA right 814	X50	5 = adds 300	1225 to 1525	
6 = Ig2 MA left 814	X50	6 = adds 300	1525 to 1825	75
7 = Ig1 MA right 814	X100	7 = adds 300	1825 to 2125	80
8 = Ig1 MA left 814	X100	8 = adds 300	2125 to 2425	

INFORMATION on operating conditions for the GL814 tubes in the SSB-600 grounded-grid linear amplifier. Loading capacitor data and readings obtained in various metering circuits also are given.

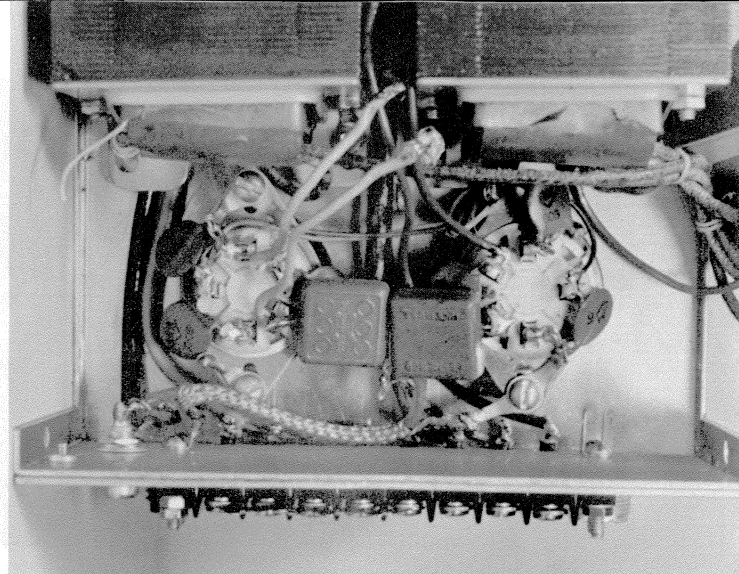

SSB-600 (continued from page 5)

peak seen on the scope by comparing the amplitude of the deflections in inches or some arbitrary units. Most scopes have translucent graphs permanently attached to the scope face. If yours does not, then attach a temporary one.

If 10 divisions on the scope face equals the 500-watt output calibration, turn up the gain until 12.2+ divisions of clean output is read. How many peak watts output is it? Remember $E^2 = \text{watts output}$ and the R

“R” in this case is a constant so the E^2 can be related directly to watts. If the first E reading equals 10, the first E^2 equals 100. Therefore, 100—500 watts. If the second E reading

equals 12.2+, the second E^2 equals 150 in round numbers. Now by the simple proportion 100:150 equals 500:X, the 12.2+ scope reading represents 750 watts peak. If your scope shows a reading on this arbitrary scale of 14+, it will be indicating a nice 1-kilowatt peak power output. Remember that when using a scope, voltage is being measured. In a given circuit, when the voltage indication doubles, the power has quadrupled. When the power in an antenna is multiplied by four, it equals 6 decibels increase in signal strength, or one big “S” unit.

All things considered, the SSB-600 linear amplifier will do a man-size job if you build it right, tune it right, and most important, operate it right!

Meters having several different full-scale current ranges were tried in this circuit at W2URP. Values of the multiplier resistances required to obtain several popular full-scale voltage readings with meters rated at from 20 to 500 microamperes have been tabulated in TABLE I — **METER MULTIPLIER CHART**. Multipliers may be assembled from two or more resistances in series to obtain the required total resistance. Five such resistances were used for the multipliers in the model constructed by W2URP.

Precision 1-percent tolerance resistances assure the best accuracy, but inexpensive composition resistors may be combined in series to obtain the correct total resistance. By selecting values carefully, the tolerances in the inexpensive resistors can thus be made to cancel each other out, resulting in a precise total value of resistance.

Shunting resistances will range from a fraction of an ohm, to a few ohms, depending upon the full-scale current range desired. They can be made from either nichrome resistance wire, or copper wire.

The exact value of shunting resistance can be determined by plugging an insulated board into J_3 and J_4 , and then connecting a short length of wire between P_3 and P_4 . A current of the desired full-scale value is then passed through the meter, and the wire is shortened or lengthened until the meter shows a full-scale reading. Shunts having a few inches of wire may be wound on 47-ohm, 1-watt composition resistors.

CONSTRUCTION DETAILS are shown in the illustrations on this page. The meter cases usually have feedthru insulators already in place. Obtain a case with a hole to fit the size of meter that will be used.

All banana jacks on the rear of the case should be insulated with the fiber washers provided with the jacks. These washers are usually adequate for several hundred volts. Wiring inside the case is run with insulated hookup wire. Standard test prods are connected to J_1 and J_2 on top of the case.

Multipliers are mounted on insulated terminal boards, and fitted with banana plugs spaced to match the multiplier jacks on the meter case.

CLOSEUP VIEW of GL-814 tube sockets with filament r.f. choke removed. Shortest leads are used on bypass capacitors on tube sockets. Capacitors in middle are 0.01-mfd. for r.f. input coupling to tube filaments.

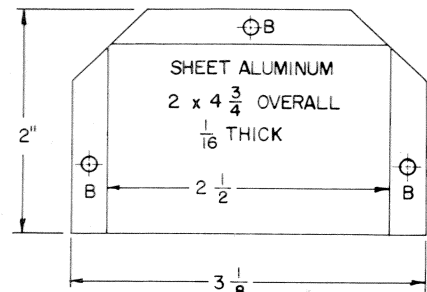

METER SHIELD — TOP VIEW

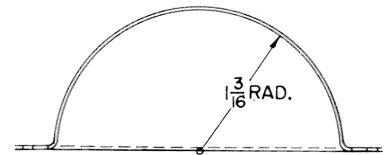

METER SHIELD — FRONT VIEW

FIG. 4. DETAIL VIEW of the metal shield which goes over the top of the meter to protect it from the plate circuit r.f. field.

A separate multiplier board is required for each voltage range.

The meter is used in the same manner as a regular multimeter. Polarity of the meter must be observed. Before checking an unknown voltage, be sure to plug in a multiplier for a full scale reading higher than the voltage is likely to be. When storing the meter, plug in a low-resistance shunt across the meter.

This simple multimeter will provide measurements of voltage accurate to within a few percent in circuits where the circuit resistance is up to 15 percent of the full-scale resistance of the multimeter. When constructed with a meter having a full-scale sensitivity of 100 microamperes or less, it will provide useful measurements of voltage in receiver and other low-level circuits.

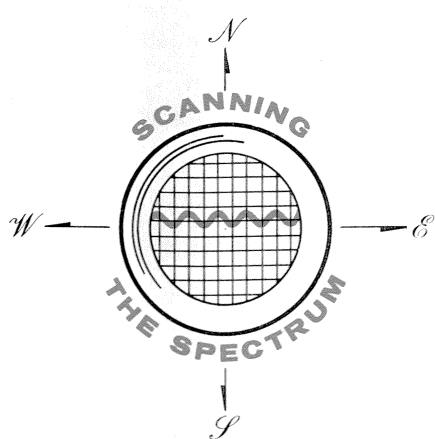

1960 EDISON RADIO AMATEUR AWARD

THE EDISON RADIO AMATEUR AWARD

... was established in 1952 by the General Electric Company to provide for public recognition of the many outstanding public services performed by radio amateurs. Many such commemorable events go unnoticed each year which otherwise could raise the stature and prestige of all radio amateurs.

The Award is presented annually to a licensed radio amateur who, while pursuing his or her hobby within the limits of the United States, has performed an outstanding meritorious service in behalf of an individual, group, or the general public.

These services range from providing vital emergency communications during emergencies, often in dangerous situations, to organizing complex communications systems, and unique services to an individual.

Candidates for the Award are nominated by letter from individuals, or clubs, associations and other groups familiar with the public service performed by their candidate.

The recipient is selected at the end of January by a panel of distinguished and impartial judges from among candidates nominated by persons familiar with the service each candidate has rendered.



Ralph E. Thomas, KH6UK

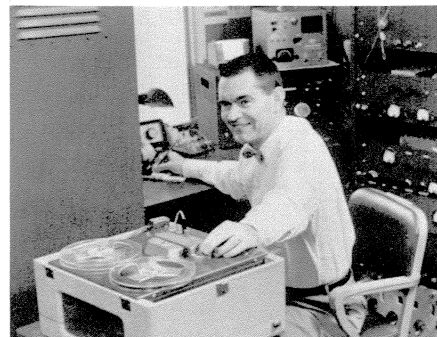

John T. Chambers, W6NLZ

... whose trans-Pacific experiments have set distance records and opened new horizons in UHF communications, have been chosen jointly by the Judges to share the 1960 Edison Radio Amateur Award for outstanding service.

This year marks the first time the award has been granted for scientific achievement. Messrs. Thomas and Chambers have devoted four long years to patient and often fruitless experimentation with tropospheric ducting radio propagation phenomena, culminating in a one-

way communications distance record of 2,540 miles on the 432 megacycle amateur band.

This and earlier two-way records set over the same California-to-Hawaii path on 220 and 144 megacycles confirmed the theory that UHF radio communications were not limited to line of sight. Their work has stimulated commercial and military interest and experimentation in communication via this phenomena.

The judging panel, in comparing their accomplishments to the first trans-Atlantic radio communications in the 1920's, noted that the work of Messrs. Thomas and Chambers further enhances the standing of amateur radio operators in the scientific world.

Judging centers on the greatest benefit to an individual, group, or community, and the amount of ingenuity, devotedness and sacrifice the candidates display in performing their services.

The presentation of the Edison Radio Amateur Award trophy and a check for \$500 to the recipient is made several weeks later at a ceremony in Washington, D. C., before prominent figures in military, government and civilian communications.

Judging the 1960 Edison Award —

E. ROLAND HARRIMAN
Chairman, American National Red Cross.

ROSEL H. HYDE
Commissioner, Federal Communications Commission.

GOODWIN L. DOSLAND
President, American Radio Relay League.



Available **FREE** from your G-E Tube Distributor

MARCH-APRIL
1961
VOL. 16, No. 2